

**Eritrea, Donors, and the Return of 500,000 Refugees:
Was there no Equilibrium Path to an Agreement?**

Richard E. Ericson and Lester A. Zeager*

Department of Economics
East Carolina University
Greenville, NC 27858

April 30, 2009

* Contact at zeagerl@ecu.edu

Eritrea, Donors, and the Return of 500,000 Refugees: Was there no Equilibrium Path to an Agreement?

Initially ... there were high hopes that the Eritrean refugees presence in Sudan would cease to exist by 1997 because of the refugees' eagerness to return, the helping hand of the international community and the country of origin, and the good will of the asylum country. As explained below, it ran into difficulty after difficulty because of contrasting actor interests and the vagaries of regional politics. (Bariagaber, 2006, 139)

Introduction

The story of the Eritrean refugees is a case study in the challenge of eliciting international cooperation for refugee repatriation and national reconstruction after the devastation of war. Their situation is one of the most “protracted refugee situations” in the world (UNHCR, 2006: 107), now extending over four decades.¹ Many international observers expected the exile to end in 1991 after Eritrea liberated itself from Ethiopia. It was hoped that 500,000 refugees could return home to rebuild Eritrea’s infrastructure and restore its environment, both of which had been devastated by more than three decades of war.

Yet their return would require the commitment of financial assistance well beyond what Eritrea believed it could possibly afford. Therefore, international donors had a critical role to play. Alas, the negotiations over a repatriation agreement between Eritrea and the United Nations High Commissioner for Refugees (UNHCR), representing potential international donors, never succeeded (McSpadden, 1999: 73). Thus, this story is also a case study of the failure to negotiate a resolution to an international (in this case,

¹ UNHCR (2006; 106) defines such situations as “refugee populations of 25,000 persons or more who have been in exile for five or more years in developing countries.” There were 27 situations of this kind in 1993 involving 7.9 million refugees, not including the Palestinians – “the world’s oldest and largest protracted refugee situation” (UNHCR, 2006; 106-8) – who are not under the mandate of the United Nations High Commissioner for Refugees.

refugee) crisis. Using a game-theoretic analysis, we model the strategic interaction that led to this disappointing outcome and explore whether changes in the parameters of the negotiations might have opened an equilibrium path to a repatriation agreement.

While the paper applies game-theoretic tools to one case, it illustrates a new approach to understanding the strategic interaction generated by the conflicting and complementary interests in refugee negotiations in other contexts. This approach seeks to capture the particular mix of interests in a refugee crisis in a strategic game, expressed in extensive form (game tree), which allows us to explain the path taken, as well as those not taken, in the negotiations. It also permits us to investigate whether a reframing of the negotiations (e.g., allowing new strategies) would have altered the equilibrium outcome and whether this outcome is robust to alterations in the players' preferences, i.e., their orderings of the possible outcomes of the interaction.

In 1991, when the negotiations considered here were getting underway, it was widely believed that the easing of Cold War tensions could open paths to the resolution of refugee crises, particularly those arising from conflicts sustained by funding from the superpowers.² As subsequent experience revealed, however, refugee crises are not only a product of the Cold War. Furthermore, the easing of that rivalry weakened one of the major reasons for Western nations, and especially the United States, to assist refugee programs. Our case features this problem, and we introduce tools for analyzing it.

The next section provides background to the refugee problem in the Eritrean situation, and tries to distill that situation into the elements of a game: the players, their

² Ethiopia, Eritrea's opponent in its long struggle for liberation, received significant financial and military backing from the superpowers – from the United States under Emperor Haile Selassie and later from the Soviet Union under Colonel Mengistu Haile Mariam (Mayotte, 1992: 227-229).

policy alternatives, and each player's rank ordering of the possible outcomes associated with the different policy combinations.³ We then present a theoretical framework that specifies "rules of play" for the strategic interaction between the players, and permits us to construct a game tree of the situation. Given a game tree, we can analyze equilibrium behavior in the game and compare it to the observed behavior in the situation, as reported by narrative accounts in the refugee studies literature. As the negotiations failed to achieve a resolution of the refugees' plight in this case, we consider how the outcome might have been different if the actors involved had framed the negotiations differently. The final section offers concluding remarks on the insights gained through undertaking this exercise.

The Situation

Background:

The flight of Eritrean refugees began in 1967, when attacks by fighters for the Eritrean Liberation Front (ELF), seeking to gain independence from Ethiopia, provoked a remarkably brutal response by the Ethiopian army (Mayotte, 1992: 230):

In 1967, following a series of attacks by the ELF in which some Ethiopian officials were killed, Ethiopian forces struck with a vengeance. Employing a scorched-earth policy, Ethiopian troops routed villagers from the rubble of their razed and looted villages and massacred them by the hundreds. Aerial raids pounded a widespread area for days, decimating herds and charring crops and fields.

After the 1967 attacks, there were other incursions by Ethiopian forces into Eritrea in the 1960s, 1970s, and 1980s (Bariagaber, 2000; 4-5). Refugees in the hundreds of thousands, the great majority of whom were Muslim pastoralists, fled the offensives of the Ethiopian

³ We do not have sufficient information to assign with any confidence cardinal payoffs to outcomes, and so limit our analysis to using purely ordinal rankings.

army and found their way to camps in Egypt or Sudan, with the largest number in Sudan. The total refugee population in Sudan in 1990 was estimated at 725,000 (Mayotte, 1992: 243), of which about 500,000 were Eritreans, based on information from the U.S. Committee for Refugees (USCR, 1996: 48).

After thirty years of war with Ethiopia for self-rule, compounded by a bitter conflict between rival guerilla forces, the ELF and the Eritrean People's Liberation Front (EPLF), Eritrea finally emerged victorious militarily, though devastated economically, in 1991 with the EPLF, a secular nationalist organization willing to embrace multiple ethnic and religious groups, in control.⁴ International recognition of Eritrea's independence was delayed, however, until a UN-sponsored referendum in 1993.⁵ The delay, combined with a lack of international support during its struggle for liberation, contributed to Eritrea's distrust of the UN and international donors in the subsequent negotiations over the repatriation of refugees from Sudan (McSpadden, 1999: 74).

UNHCR, representing several potential donor countries (Canada, Finland, Germany, the Netherlands, Norway, Sweden, Switzerland, and the U.S.) began bilateral repatriation negotiations with Eritrea, opting not to include Sudan, the country of asylum, owing to tensions between the two countries (Rock, 1999: 134; McSpadden, 1999: 70).⁶ The formal negotiations began in 1991, following earlier informal discussions. UNHCR

⁴ McSpadden (1999) notes that the population of Eritrea is evenly divided between Muslims and Christians, but also includes adherents of indigenous African religions.

⁵ During the long struggle for liberation, Ethiopia received far more international support (from different countries at different times) than Eritrea. Not surprisingly, these countries were slow to recognize Eritrea as an independent country. UNHCR was also reluctant to deal with entities lacking the status of sovereign states (Bariagaber, 1999: 609; McSpadden, 1999: 74).

⁶ The Eritrean government has alleged Sudanese support for the infiltration of its western lowlands by Muslims promoting a fundamentalist agenda (Rock, 1999: 134).

opened a permanent office in Asmara in November of that year (McSpadden, 1999: 70-74).

Eritrea came into the negotiations with enormous needs. Three-fourths of its population needed food relief to survive the first year after the war (1991-92), requiring 100 ships at sea at any one time to meet the need (Mayotte, 1992: 296). War was not the only cause of famine in Eritrea; rainfall reached normal levels only one year (1986) in ten during 1981-1990 (Rock, 1999: 130). The war destroyed nearly all the infrastructure of the country and degraded its environment (McSpadden, 1999: 72). Therefore, Eritrea needed financial assistance for relief, repatriation, and reconstruction.

The EPLF had concerns that the mostly Muslim returnees, many of whom had historical ties to the EPF (McSpadden, 1999: 73) and who had been under the influence of Islamic fundamentalism in Sudan (in schools financed by Saudi Arabia), might disturb Christian-Muslim relations in Eritrea and seek to undermine the government's legitimacy (Pool, 2001: 192). Yet, throughout its long war with Ethiopia, the EPLF had maintained offices in the refugee camps in Sudan where it recruited fighters, thus giving it ties to the refugees (Pool, 2001: 129-30). Indeed, the leader of the EPLF and the head of the new government in Eritrea took a favorable view of a return by the refugees (Mayotte, 1992: 289):

Isaias Afewerki ... seemed anxious to have the Eritrean refugees return. He believed that all Eritreans could help rebuild the land and urged all Eritreans, including those who opted for permanent asylum, even citizenship in other countries, to return, at least temporarily, to participate in Eritrea's reconstruction.

The international community also favored their return. So long as conditions in the country of origin are safe, UNHCR regards repatriation as the best of the three classic

solutions for refugees: repatriation to the country of origin, local settlement in the country of asylum, and resettlement to a third country. In his review of international perspectives on refugee assistance, Zetter (1999: 59) recognizes, “quite simply, repatriation has been promoted by the international community and host countries to relieve the costs which protracted large-scale displacements impose.” Thus, international donors shared an interest in repatriation.

In the early 1990s, however, the great majority of international donors were preoccupied with two developments elsewhere: (1) the breakup of the Soviet Union and (2) the Persian Gulf conflict. With the easing of the Cold War, Eritrea’s location near the Red Sea lost much strategic significance. Hence, while several donors expressed interest in cooperating with repatriation (McSpadden, 1999: 84), their global priorities would not support an expensive operation. Yet Eritrea had great needs – relief, refugee repatriation, and reconstruction – that it was in no position to finance, so a conflict of interest arose in which Eritrea demanded substantial financial assistance before accepting the burden that the international community was trying to offload.

In 1991, the easing of hostilities in the country of origin led to a round of negotiations over the fate of the exiles. A successful outcome required repatriation, at least to a large extent. Such an outcome failed to occur, however, so the exile stretched over years – indeed, many of the refugees remain in exile to this day. The failure to end the exile creates a puzzle, which we explore in a formal model to better understand why negotiations in the most opportune period (1991-95) failed,⁷ and whether there was a possibility of a better outcome.

⁷ The best account of the negotiations (McSpadden, 1999), which is based on extensive personal interviews with participants in the negotiations – officials from the country of origin and numerous donor countries, as

The Model: Players, Strategies, and Preferences

In his analysis of repatriation negotiations in the Horn of Africa, Bariagaber (1999, 608) argues that negotiations of this kind involve at least four primary actors: “UNHCR, the refugee origin state, the refugee host state, and the individual refugee.” Yet, not all play an equal role. State-level actors strongly influence the environment in which the refugees must act, limiting and otherwise molding the opportunities they face. Obviously, repatriation involves individual decisions by refugees on whether to return to the country of origin, but those decisions are either independent of, or subsequent to, the negotiations for a repatriation agreement. Furthermore, the *individual* refugee is clearly an “atomistic” agent without direct influence on the negotiations, although spontaneous movement of many refugees can influence their course.⁸ Finally, as mentioned above, UNHCR excluded the refugee host state (Sudan) to appease the refugee origin state (Eritrea) at the outset of the negotiations in this case (Rock, 1999: 134).

Thus, we model the repatriation negotiations as a two-player game involving Eritrea, the country of origin, and UNHCR, representing donors capable of providing assistance for repatriation and other needs. The first step in developing an analytically

well as staff members of various UN organizations that represented the donor countries in the negotiations – treats 1991-95 as a distinct phase of negotiations. For information on developments since 1995, see U.S. Committee for Refugees (2001) and Bariagaber (2006, Chapter 8). Of more than 500,000 Eritrean refugees in Sudan in mid-1991, about 18 percent repatriated by May 1995, about 36 percent repatriated by 1998, and approximately 62 percent repatriated by 2004. Hence, nearly a decade after the period we consider in this paper, more than one-third of the refugees remained in Sudan.

⁸ Such a spontaneous movement is not part of a coordinated, collective decision by the refugees as a coherent whole, but the aggregate result of (largely independent) individual decisions. By taking this approach, we limit ourselves to explaining whether the state-level players reach agreement on (including the provision of funding for) a repatriation program, and thus offer the refugees an improved *opportunity* for repatriation. Bariagaber (2000: 7) cites an estimate from UNHCR that some 30,000 Eritrean refugees in Sudan might choose not to return, even if given the opportunity.

useful, formal game model of this strategic interaction is to specify the set of policy decisions, or the “strategy spaces,” open to the two agents.

Based on our reading of this situation, we allow Eritrea two strategic choices: support or oppose a repatriation agreement. It could oppose a repatriation agreement by frustrating UNHCR initiatives or even limiting its activities in the country. Yet, it would not be easy, especially for a poor country, to monitor its borders to prevent refugees from returning spontaneously. Thus, opposing a repatriation agreement does not mean that no repatriation occurs, but it surely limits the flow of refugees returning from exile.

The strategies available to UNHCR and its donors were also limited in the negotiations. As McSpadden (1999: 76) reports, “PGE [Provisional Government of Eritrea, which ruled Eritrea from its 1991 liberation from Ethiopia to the UN-sponsored referendum in 1993] insisted that only plans for the *total repatriation programme* for the 500,000 refugees should be developed and funded.” [italics in original] Further, Eritrea insisted that international assistance cover all of its relief, repatriation, and reconstruction needs. As a member of the UN mission to Eritrea remarked in December 1991 (Mayotte, 1992: 290),

They [the Eritreans] are being very unrealistic about what they're going to get out of the donors. They classified their entire reconstruction needs – schools, hospitals, roads, and everything else – as emergency needs deriving from the war. It's as if they want foreigners to give them the infrastructure of a middle-income country, all in one fell swoop.

Thus, we allow UNHCR and its international donors two strategy choices: minimal or generous assistance. Minimal assistance represents the status quo (some food and other relief to the population within Eritrea). Generous assistance would cover repatriation and reconstruction needs, in addition to relief.

The next step in the identification of the model is to give a clear summary of the consequences of each possible pair of policy decisions by the two agents, each of which generates a situation with respect to which the agents (players) have preferences that will guide their choices. With two players choosing between two policy options each, there are four possible configurations of policies, which we will call “states of play.”

Consider two possible states brought into play by the limited interest of international donors in funding a UNHCR initiative in Eritrea, both of which involve minimal assistance, primarily for relief purposes. In one of these states, Eritrea supports the repatriation agreement. Here the available international assistance would go to either relief or repatriation, but relatively few exiles would be able to return to their homes with minimal assistance. Furthermore, Eritrea’s reconstruction would be hindered by a lack of international aid.⁹ Eritrea’s alternative policy, opposing a repatriation agreement, leads to a different state of play in which the flow of returnees becomes quite small, with the very limited international assistance going only for relief to the general population rather than for repatriation of the exiles. Here reconstruction would remain slow, but fewer internal resources would be diverted to addressing the needs of returnees.

A switch in policy by UNHCR would “open the doors” to the third and fourth states, each having generous assistance. In the third state, Eritrea opposes a repatriation agreement, so the assistance would cover reconstruction costs – potentially boosting the development of the country – but not repatriation, which could keep the flow of refugees slow. To reach the fourth state of play, Eritrea has to support the repatriation agreement, and with generous assistance from the international community, most of the exiles would

⁹ The urgency of dealing with the returnees and their problems would absorb the lion’s share of the available economic resources.

return home with ample resources for their reintegration and for the reconstruction of the country. One aim of this paper is to investigate ways in which the players might reach agreement on this outcome – which refugee advocates hoped to achieve – as the final state of play.¹⁰

The third step in the specification of the formal model requires us to assign objectives or preferences, i.e., ordinal rankings of the states described above for each player. Based on the discussion above, Eritrea’s highest priority in the negotiations was to obtain generous assistance, which allows us to divide the four possible states into two better and two worse states for Eritrea. The information we have already presented about the government’s attitudes toward the refugees suggests that Eritrea favored a repatriation agreement if assistance was generous, but not if assistance was minimal. Hence, its worst state is when it supports a repatriation agreement – facilitating a large influx of refugees – and UNHCR provides minimal assistance. Dealing with the returnees would then totally overwhelm Eritrea’s resources. At the other extreme, the best state for Eritrea is when it supports a repatriation agreement and UNHCR provides generous assistance, for this state best facilitates reintegration and reconstruction.¹¹

As the international agency charged with refugee protection and assistance, UNHCR clearly favored repatriation, and donors shared that interest, at least to some degree. Thus, for any given level of assistance, we believe that UNHCR preferred for Eritrea to permit repatriation. Yet, the difficulties of eliciting funds from donors forced

¹⁰ That is, we investigate whether there is an “equilibrium path” in the extensive-form game that we will use to analyze the interaction of the players in this situation.

¹¹ Indeed, given sufficient resources, the returning refugees are a key asset for development, providing critical human capital, rather than being an additional welfare burden.

UNHCR to favor the states with minimal assistance over those with generous assistance, whether Eritrea facilitates repatriation or not.¹² Thus, the best state for UNHCR would be where Eritrea supports a repatriation agreement with minimal assistance from the donors (resolving the longstanding exile inexpensively), and the worst state would be where the international community provides generous assistance for relief and reconstruction, yet Eritrea opposes a repatriation agreement (creating an expensive burden but leaving the refugee problem unresolved).

We can now summarize the ordinal rankings of the players, with UNHCR's ranking listed first in each ordered pair:¹³

- **s_1 = (Minimal Assistance, Support a Repatriation Agreement):** *The best state for UNHCR, because the door opens for the refugees to return without additional funds from the donors. The worst state for Eritrea, because it threatens to impose an overwhelming burden on the country. Payoffs: (4,1)*
- **s_2 = (Minimal Assistance, Oppose a Repatriation Agreement):** *The next-best state for UNHCR (and more specifically, its donors), because it avoids the most costly solution, but the repatriation negotiations stall. The next-worst state for Eritrea, because it limits the refugee burden but fails to obtain assistance for reconstruction. Payoffs: (3,2)*
- **s_3 = (Generous Assistance, Oppose a Repatriation Agreement):** *The worst state for UNHCR, because it must raise enormous funding yet Eritrea blocks the return of the refugees. The next-best state for Eritrea, because it obtains a great deal of assistance for reconstruction yet the exiles do not come home. Payoffs: (1,3)*
- **s_4 = (Generous Assistance, Support a Repatriation Agreement):** *The next-worst state for UNHCR, because the proposal costs more than donors are willing to provide, but it brings Eritrea on board, which facilitates repatriation. The best*

¹² We envision this position as an institutional orientation to reality, not necessarily reflecting the attitudes and beliefs of those who worked at UNHCR.

¹³ We call the states “best” (4), “next-best” (3), “next-worst” (2), and “worst” (1), where the numbers represent the ordinal payoff – highest to lowest – to each player. The source materials for these rankings include Bariagaber (1999, 2000, 2006), Bascom (1994), Mayotte (1992), McSpadden (1999), Pool (2001), Rock (1999), and USCR (1996).

state for Eritrea, because the proposal contains the necessary assistance and opens the door for refugee return. Payoffs: (2,4)

These four states and the payoffs associated with them for each player could be conveniently summarized in normal form, using a 2x2 payoff matrix similar to the one shown at the bottom of Figure 1, where the row player is UNHCR/donors and the column player is Eritrea. This representation alone, however, is inadequate as a description of the strategic interaction between UNHCR and Eritrea, for it fails to capture the give and take, proposals and counterproposals, in the course of the negotiations. Hence, we choose to model the game in extensive form, with an initial state of play, s_i , and a set of rules of interaction generating a game tree (Figure 1), as the next section will show.

Thus, we need to determine the initial state of play (policy combination for the players at the beginning of the negotiations or strategic interactions). To do so, we need information on the international assistance flowing into Eritrea and on its policy toward repatriation when it achieved liberation from Ethiopia in May 1991. With regard to international assistance, Rock (1999, 130-131) observed that

A clearly defined division of labour [existed] between international food donors, the NGOs and the Fronts' relief organizations—the Eritrea Relief Association (ERA) and the Relief Society of Tegray (REST) [the latter was operating in a disputed region in northern Ethiopia, rather than in Eritrea]. ... In practice, the NGOs' activities were restricted to funding and transport of food and other relief commodities, and to the monitoring of the operation. ERA and REST took sole responsibility for the coordination, implementation and delivery of all food and non-food aid in their respective liberated areas. ... the relief aid available to ERA and REST was always far short of actual needs.

Rock (1999: 131) also notes that,

The aid provided by the ultimate bilateral donors and the NGOs was not restricted to food, but also included non-food inputs: transport, cash, seed and agricultural implements, which allowed the relief agencies to engage in relief and rehabilitation activities simultaneously.

While this description includes some items that go beyond relief, the assistance seems “minimal,” especially compared to the proposals made by the Eritrean government in the negotiations, as we will see in the next section. With regard to repatriation, Mayotte (1992: 285) reports that,

A spontaneous return of refugees, without international assistance from UNHCR, began almost immediately after peace was declared. The village of Teseney just across the border from the Sudanese town of Kassala became the point of entry for the first hundreds and then thousands. In less than a year, more than twenty thousand had crossed the border to Teseney. Its population of 2,500 swelled to 10,000, an impossible number of people for Teseney’s limited infrastructure. Housing, water supplies, medical facilities, and schools were strained to breaking. Still refugees continued to return – at the rate of one hundred a day.

This report supports the statements (quoted above) by Isaias Afewerki, the head of the EPLF, favoring the return of exiles. We can already see that Eritrea could sustain this strategy only with outside assistance. As the next section will show, Eritrea’s initial proposal to UNHCR called for repatriation with very generous assistance.

Based on this review of the narrative literature, s_1 , “minimal assistance with Eritrea supporting a repatriation agreement,” was the initial state, i.e. the combination of policies at the outset of the negotiations. The quote immediately above shows that this state allowed 20,000 refugees to return to Eritrea in 1991. The experience, however, turned Eritrea against efforts to devise a repatriation program at the assistance levels that donors would support. Thus, in our model, Eritrea makes the first move from the initial state by switching its strategy from supporting to opposing a repatriation agreement.

Game-Theoretic Analysis

To analyze our model, we need to specify “rules of play” governing the interactions between UNHCR and Eritrea in the refugee negotiations. We find the Theory of Moves (ToM) by Willson (1998) a useful specification for our cases.¹⁴ ToM comprises a set of simple dynamic (extensive-form) stage games derived from allowing players in a 2x2 bi-matrix game alternating turns to switch their policies in pursuit of an ultimately better outcome (i.e., higher payoff). Each game begins at some initial policy combination and payoff configuration, and one player has the first turn to “move.” Each policy switch is a move, to which the other player responds by moving or “passing,” i.e., maintaining its policy and remaining in the most recent state. Turns to move alternate strictly between the players and there is a given, finite, maximum total number of moves (not counting passes) allowed in each game. Payoffs are only awarded when play ends, and are determined by the final policy combination. The payoffs are purely ordinal, rendering convex combinations (probability mixtures) ill-defined.

The game ends when two players *pass consecutively*, signaling agreement, or reach the maximum number of moves allowed in the game. Therefore, the interactions resemble a bargaining process with a deadline. Given a set of payoffs for each player, an initial state, and a first mover, ToM predicts equilibrium paths to an “ultimate outcome” (UO) of the interaction. For many 2x2 (and larger) payoff matrices, including the ones

¹⁴ Willson (1998) is a significant revision of the original version of ToM by Brams (1994), changing the way the game begins and ends, allowing for more than two strategies for each player, and developing the analysis with more mathematical rigor.

considered in this paper, the UO does not depend on the time horizon (the number of moves allowed in the game) above a low threshold.¹⁵

With initial state s_1 and the column player, Eritrea, making the first move (by switching its policy from supporting to opposing a repatriation agreement, moving the game to a different state, s_2), the game tree in Figure 1 represents the extensive form of the game under the rules of play in Willson (1998). The total number of moves allowed in the game in Figure 1 is fixed at $n = 4$, which exceeds the threshold necessary for a UO independent of n .¹⁶ We can find the UO in a finite game by backwards induction; Figure 1 shows in bold the optimal choices at each node in the game tree.¹⁷ Continuous bold arrows from the initial state trace equilibrium paths to the UO, the final state s_2 with payoffs (3,2), “minimal assistance with Eritrea opposing a repatriation agreement.” The ordered pair shows the rank orderings of the final state by the row player, UNHCR, and the column player, Eritrea, respectively, where a higher number denotes a more desirable state. Thus, ToM predicts that the UO will be the next-best state for UNHCR and its donors and the next-worst state for Eritrea.

Insert Figure 1 here

¹⁵ Willson (1998: 217) shows that any strict 2x2 game is “either ultimately constant [yields the same ultimate outcome, regardless of the number of moves allowed in the game] or else ultimately alternating [switches between two ultimate outcomes, depending on whether the number of moves allowed in the game is even or odd].” In this application, the game is ultimately constant.

¹⁶ We determine this threshold from a computer program for tracking the optimal moves in the revised version of ToM, created by Steven Willson and translated by one of the authors into Gauss. The translated program is available from the authors upon request.

¹⁷ Two branches from the same decision node cannot lead to the same terminal node, but they can lead to the same final outcome (e.g., the first node for R in Figure 1, where a pass and a move both lead ultimately to the final state s_2). In such cases, both branches from the player’s decision node are shown in bold.

Figure 1 shows two possible equilibrium paths to this UO.¹⁸ The shorter path involves one move (the column player, Eritrea, switches its policy from supporting to opposing a repatriation agreement), followed by two consecutive passes, which ends the game. The longer equilibrium path involves three moves. The first move overlaps with the shorter path; the other two moves are by the row player, UNHCR, which switches to generous assistance and then reverts to minimal assistance after a pass by Eritrea.¹⁹ Once again, the game ends with two consecutive passes. Therefore, neither equilibrium path uses all four moves available to the players.

To evaluate the predictions of the theory, we compare them to a substantial account of the negotiations by McSpadden (1999) and with information gleaned from other literature on the crisis. In the chronology of events by McSpadden (1999: 75), we can see clearly that Eritrea entered the negotiations supporting a repatriation agreement,

In autumn 1991 PGE presented a budget for U.S.\$300 million for a comprehensive program of return and reinsertion, apparently with the understanding that UNHCR had responsibility for all aspects of the refugees' return including its extension into national development. ... PGE insisted on placing repatriation within a total development approach for the entire country.

But, the proposal by Eritrea was not in keeping with the priorities of potential donors, as understood by UNHCR (McSpadden, 1999: 76):

UNHCR, however, stated that donors would not fund development activities by UNHCR. ... for example, UNHCR would not replace the water system in Massawa, but would dig a small number of tube wells.

A few months later, the UNHCR fashioned its appeal to donors, but Eritrea intervened (McSpadden, 1999: 76),

¹⁸ If we increased the value of n , there would be more (and longer) paths to the same UO.

¹⁹ This path shows the row player exploring the possibility of returning to s_1 , its best state, (which the row player can only do by moving in a counter-clockwise direction in the payoff matrix), but the column player blocks the way by refusing to move from s_3 to s_4 , so the row player returns to s_2 , which is its next-best state.

In December 1991 the first international appeal for Eritrea was posted. UNHCR estimated an initial requirement for U.S.\$50 million, stressing that they did not expect to receive the full amount immediately. ... [However,] PGE refused to allow UNHCR to begin discrete, preliminary projects.

Mayotte (1992: 290) describes a similar impediment,

The UNHCR devised a plan and budget for bringing home 250,000 in the first year. The Provisional Government of Eritrea [PGE] rejected the proposal, protesting that such limited funds would leave the refugees destitute in an already destitute land. The PGE wanted a fourfold increase. In addition, the PGE asked for immediate funding of a broad-reaching blueprint while the UNHCR wanted to take a step at a time, particularly in funding.

Bariagaber (2006, 139) adds that the total cost of the repatriation was estimated at US\$ 200 million by the Eritrean government, compared to US\$ 30 million by UNHCR. In these reports we see the switch in strategy by Eritrea from supporting to opposing a repatriation agreement, thus moving to state s_2 (“minimal assistance with Eritrea opposing a repatriation agreement”) in the Figure 1 game.

The two possible equilibrium paths diverge at the decision node where the row player (UNHCR/donors) has its first turn to move. That decision was delayed until the UN referendum in April 1993 that established Eritrea’s sovereignty and opened the way for direct assistance to the new government.²⁰ From McSpadden (1999, 77), the decision by the row player (UNHCR/donors) is quite clear,

After the April 1993 referendum ... A repatriation plan was developed in close consultation between UN, PGE, NGOs and donor governments. DHA [the UN Department of Humanitarian Affairs] presented the ‘Joint Government of Eritrea and United Nations Appeal for Eritrea’ (PROFERI) to more than 120 governments and aid organizations at a donors’ conference. ... Under this plan all of the refugees in Sudan (estimated at over 400,000) would be enabled to return and be reintegrated in Eritrea. The total cost was estimated at U.S.\$262 million. However, the pledges in response to this appeal amounted to U.S.\$32.4 million of which only U.S.\$11 million was new money. The remainder was food

²⁰ According to Bascom (1996, 67), “... only one seventh of the refugee population in Sudan [roughly 70,000 persons] returned during the 12 months preceding the end of the armed conflict as well as the first two years thereafter.”

aid through the World Food Programme and would have been available in any case.

Here UNHCR/donors passed at their first turn to move in Figure 1, taking the players along the shorter equilibrium path rather than the longer one. The proposed assistance level was not the only problem for the donors: they had reservations about disregarding UNHCR's mandate (venturing beyond repatriation to development), commencing before agreeing on specific project plans, and exclusive reliance by Eritrea on national project management, thereby limiting NGOs (typically based in the donor countries) to only monitoring and evaluation (McSpadden, 1999: 77-79).

At this point, Eritrea, the column player, faced a choice to pass (thus ending the game at s_2) or move (thereby returning the game to s_1 , the initial state, and allowing play to continue). From McSpadden (1999: 75), it is clear that Eritrea did not make the move,

The outcome was that after nine months of negotiations, UNHCR and the provisional government of Eritrea were unable to reach an agreement regarding an organized repatriation programme for the refugees in Sudan. The UNHCR office in Asmara was no longer operational.

Like the donors, Eritrea had several reasons for withholding support for a repatriation agreement: it perceived discrimination in UNHCR's repatriation package in comparison to packages negotiated in other situations (South Africa, Namibia, and Cambodia) and the prospect of entering into a repatriation program without "full, guaranteed funding was too risky" (McSpadden, 1999: 78). Likewise, Mayotte (1992: 290) notes that Eritrea insisted on assistance comparable to the repatriation packages for Cambodia and Namibia, e.g., \$900 per head offered to the Namibians rather than the \$200 per head offered to the Eritreans.

Even though negotiations for a full repatriation program had broken down, UNHCR and other UN agencies continued to discuss small-scale possibilities with the Eritrean government. The discussions led to a pilot project involving a small portion of the exiles in Sudan (about 20,000 – fewer than had returned in 1991 at the conclusion of the civil war) in 1994-95, with Eritrea providing U.S.\$7.5 million in start-up money, but the repatriation did not advance beyond the pilot phase (McSpadden, 1999: 77-78). From Bariagaber (2006, 138) we learn that, “... the self-repatriation of Eritreans, which began in 1990, continued until the late 1990s despite lack of any assistance to reconstitute the ruined home areas.” Thus, we conclude that the prediction of s_2 (“minimal assistance with Eritrea opposing a repatriation agreement”) as the UO of the interaction, with the players taking the shorter equilibrium path to that UO in Figure 1, fits the narrative evidence reasonably well.

Of course, this outcome was no solution to the refugee’s plight. Refugee advocates had hoped to attain s_4 as a final state (“generous assistance with Eritrea supporting a repatriation agreement”), instead of s_2 (“minimal assistance with Eritrea opposing a repatriation agreement”). Notice that Figure 1 has two paths leading to the outcome s_4 . Therefore, we need to ask, why did the players not follow these paths? The answer that emerges from an analysis of Figure 1 is that the actors in a position to make it happen found that outcome to be not in their interest. Consider first the path to s_4 on the left side of Figure 1. Here the row player (UNHCR/donors) has an incentive to defect from the hoped-for path at two decision nodes. The first defection is a pass at s_1 (its best state), leading ultimately to its next-best state, s_2 . The second defection is a move from s_4

(its next-worst state) that leads ultimately to its best state, s_1 . Thus, so the row player has no incentive to follow that path to s_4 .

Now consider the other path to s_4 on the right side of Figure 1. Here the row player (UNHCR/donors) has an incentive to defect from the hoped-for path by moving from s_4 to s_1 , its most preferred state. Again, there is no incentive for the row player to cooperate. Note also that the column player, Eritrea, defects along this path (passing at s_3 after the second move), but only because it anticipates the other player defecting after the third move (moving to s_1). Thus, given the structure of the underlying incentives of the strategic interaction (with only two stark alternatives available), the desired outcome of refugee advocates could not be aligned with the interests of international donors who finance repatriation agreements via UNHCR. The impediments to cooperation are strikingly similar to the following assessment by Bariagaber (2006, 140):

Thus, the need for UNHCR to resolve a long-lasting problem with minimal funds and to show the increasingly impatient donor community that [it] can deliver, on the one hand, and the inability of the Eritrean government to support massive refugee return only a year to two after independence, on the other, created the first roadblock on the way to a successful assisted repatriation.

The logic of the strategic situation, the given preferences, and the perceived strategic alternatives of the actors seem to imply the inevitability of the actual outcome, undesirable from the perspective of refugee advocates. Was a standoff at the state-actor level, with a trickle of minimally-supported refugees returning from exile and most others stuck in deteriorating circumstances in camps outside Eritrea, inevitable? What might it have taken, other than a reversal of core interests by the key parties to the negotiations, to achieve a more desirable outcome? In particular, would it have been possible to reach a

more desirable resolution if the key actors had framed the situation differently, even while maintaining their core interests?

Thus, we are led to ask what changes in the parameters of the game would be necessary to achieve an outcome with greater repatriation and international assistance? Of course, reaching s_4 would be trivial if UNHCR/donors, the row player, had different preferences (i.e., if they ranked s_4 as their best state). Not infrequently, refugee advocates propose solutions along these lines, as McSpadden (1999: 84) does in this case,

Everyone – UNHCR, donors, the government of Sudan, and the government of Eritrea – says that repatriating the refugees is of the highest priority. What is needed is goodwill and cooperation to make such statements truth rather than rhetoric.

In contrast to this approach, the next section explores whether more modest changes to the parameters of the game – based on ideas that emerged in the actual negotiations – might have opened an equilibrium path to greater assistance and repatriation.

Could an Expanded Game have Opened a Path to an Agreement?

The previous section has documented instances in which Eritrea blocked efforts by UNHCR to introduce intermediate options between minimal and generous assistance, such as pure repatriation with no reconstruction or development features, i.e., “[a] census in camps, transportation, way stations, some sort of reception, some beginning basics the refugees will need to get started, like seeds...” (McSpadden, 1999: 80), or any piecemeal strategy relying on initial demonstrations of success as a basis for further appeals. Might an increase in Eritrean negotiating flexibility, if not a change in preferences, have opened the door to a better outcome from the perspective of the refugee community? We answer the question by enriching the structure of the formal model – expanding the strategy set

available to the row (UNHCR/donors) player to include “intermediate assistance,” which includes relief and repatriation assistance but not reconstruction funding. With the new strategy, the payoff matrix expands in dimension to 3x2, as shown at the bottom of Figure 2, and the game tree expands as well (Figures 2 to 5).²¹

In the 3x2 payoff matrix, the payoff ordering – now made with rankings 1 to 6, rather than 1 to 4 – for the column player (Eritrea) follows patterns in keeping with the specification in the previous section. First, it always favors receiving more assistance to less. Second, Eritrea favors a repatriation agreement, except when assistance is minimal. Bariagaber (2996, 139) reports that, “... the government of Eritrea was very receptive – indeed enthusiastic – to the idea of assisted repatriation, provided sufficient funds were available to help the refugees resettle and start a new life.” As in the 2x2 specification, UNHCR and donors prefer a repatriation agreement for any given level of assistance. They also wish to avoid generous assistance, but their rankings of states with minimal and intermediate assistance are more difficult to specify. We assume they most prefer “minimal assistance with Eritrea supporting a repatriation agreement,” as in the previous section, but at the lower assistance levels, reaching a repatriation agreement has a higher priority than the cost of the program. The latter assumption is indicated in Figures 2 to 5 by the second- and third-best states for UNHCR/donors.²²

With a new strategy for the row player (UNHCR), its decision nodes must all have three branches, complicating the game tree considerably, so we cut it into sections, shown in Figures 2 to 5. We can still analyze the choices of the players using backwards

²¹ Even in the expanded game, four moves suffice to reach the ultimate outcome.

²² We will consider the consequences of reversing this priority below.

induction to obtain the optimal choices, shown in bold. Continuous paths of bold arrows from the initial state indicate the equilibrium paths to the UO. Figures 2 to 5 reveal that the new strategy and specified preferences generate the UO “intermediate assistance with Eritrea supporting a repatriation agreement,” the final state s_4 with payoffs (5,4) in Figure 3. This state is the “next-best” for UNHCR and the “third-best” for Eritrea. Hence, we find one equilibrium path to the UO involving four moves.²³ The column player (Eritrea) makes the first and last moves this time, first opposing and later supporting a repatriation agreement, and the row player (UNHCR/donors) makes the other moves, first proposing generous assistance (at s_6 in Figure 2) and then reducing it to intermediate assistance (at s_3 in Figure 3). After Eritrea’s last move, the game ends at s_4 in Figure 3. Interestingly, Eritrea chooses to pass at state s_6 in Figure 2, anticipating that if it moved to s_5 , its best state, the row player (UNHCR/donors) would “defect” by moving to s_1 , its best state.

While the new parameters for the game show that an equilibrium path to cooperation is possible, the outcome remains fragile. That is, the prospects for success depend on how the UNHCR/donors assign preferences to the new states made possible by the increased flexibility of Eritrea. Suppose, for example, that we slightly changed the preferences for UNHCR/donors, such that their ordering of the “second- and third-best” states (s_4 and s_2 , respectively) is reversed. This revision generates the game tree shown in Figures 6 to 9, where the UO reverts to the final state s_2 , “minimal assistance with Eritrea opposing a repatriation agreement,” in Figure 7. This sensitivity of cooperation to the

²³ Other equilibrium paths would likely emerge if we allowed more than four moves in the game.

preferences of UNHCR/donors is one possible reason for Eritrea to be skeptical of UNHCR proposals introducing an intermediate strategy in the negotiations.²⁴

Our analysis suggests that some give-and-take was essential on both sides to achieve more repatriation. Certainly, UNHCR (and its donors, in particular) had to be more inclined to provide assistance, but to make this shift more feasible, Eritrea needed to allow an intermediate strategy for donors at the bargaining table. Unfortunately, the lack of trust between the parties precluded this kind of give-and-take.

Conclusions

We have used a formal, game-theoretic model to represent the strategic interaction in the (failed) refugee repatriation negotiations of 1991-95 between Eritrea and UNHCR, representing potential international donors. In the model, the equilibrium path to the “ultimate outcome” of the interaction fits the available narrative evidence in the refugee studies literature. The extensive form of the game tree also shows why the player’s incentives kept them from reaching the outcome for which refugee advocates had hoped – generous assistance from international donors with Eritrea supporting a repatriation agreement. Within the framework of the negotiations, the international donors working with UNHCR had incentives to defect from such cooperation. By formalizing the analysis, we are able to present these issues with more clarity and precision than one finds in the existing narrative literature of refugee studies.

²⁴ Along these lines, we point out that reversing the ordering of the next-best and next-worst states for UNHCR/donors in the 2x2 game of the previous section would be sufficient to induce cooperation (i.e., “generous assistance with Eritrea supporting a repatriation agreement”) in ToM. This payoff configuration would correspond to game 28 in Willson (1998: 236) rather than game 26, which yields a different UO. Of course, this preference reversal is stronger than the one considered in this section, as it involves generous assistance, which would be far more costly for the donors.

We have also considered whether expanding the strategies available to international donors, in directions that UNHCR was unable to convince Eritrea to explore, could have opened the door to a better outcome for the refugee community. Expanding our model by adding an intermediate strategy for international donors and UNHCR shows a possibility for achieving the desired cooperation, but this possibility is sensitive to small changes in the preferences of the international community. Overall, these exercises show the importance of the framing of the negotiations and of the perceptions that the players bring to the negotiations about what is possible.

The ideas presented here can be viewed as an application of the “analytic narrative” approach to understanding important events in political science, economics, and history (Bates, *et. al.*, 1998). We distill the narrative accounts into an extensive-form game, and seek to explain the main course of events and the outcome as an equilibrium of the game. We show that a parsimonious specification, combined with explicit and formal lines of reasoning, helps us to see where the parties might have found common ground, and the degree to which the key players needed to bend to achieve the cooperation necessary to alleviate the plight of the refugees.

References

- Bates, Robert H., Avner Greif, Margaret Levi, Jean-Laurent Rosenthal, and Barry R. Weingast (1998). *Analytic Narratives*. (Princeton: Princeton University Press).
- Bariagaber, Assefaw (1999). "States, international, organizations and the refugee: reflections on the complexity of managing the refugee crisis in the Horn of Africa," *The Journal of Modern African Studies*. 37/4: 597-619.
- _____ (2000). "Eritrea: Conflict and Involuntary Population Displacements," *United Nations High Commissioner for Refugees: Centre for Documentation and Research*, WRITENET Paper No. 05/2000.
- _____ (2006). *Conflict and the Refugee Experience: Flight, Exile, and Repatriation in the Horn of Africa*. (Burlington, VT: Ashgate Publishing Company).
- Bascom, Johnathan (1994). "The Dynamics of Refugee Repatriation: The Case of Eritreans in Eastern Sudan," in W.T.S. Gould and A.M. Findlay, eds., *Population Migration and the Changing World Order*. (West Sussex, UK: John Wiley & Sons Ltd) 225-248.
- _____ (1996). "Reconstituting Households and Reconstructing Home Areas: The Case of Returning Eritreans," in Tim Allen, ed., *In Search of Cool Ground: War, Flight & Homecoming in Northeast Africa*. (Trenton, NJ: Africa World Press) 66-79.
- Brams, Steven J. (1994). *Theory of Moves*. (Cambridge: Cambridge University Press).
- Mayotte, Judy A. (1992). *Disposable People?: The Plight of Refugees*. (Maryknoll, NY: Orbis Books).
- McSpadden, Lucia Ann (1999). "Contradictions and Control for Repatriation: Negotiations for the Return of 500,000 Eritrean Refugees," in Richard Black and Khalid Koser, eds., *The End of the Refugee Cycle?: Refugee Repatriation and Reconstruction*. (New York: Berghahn Books) 69-84.
- Pool, David (2001). *From Guerillas to Government: The Eritrean People's Liberation Front*. (Oxford, UK, and Athens, OH: James Currey and Ohio University Press).
- Rock, June (1999). "Relief and Rehabilitation in Eritrea: Lessons and Issues," *Third World Quarterly*. 20/1: 129-142.
- United Nations High Commissioner for Refugees (2006). *The State of the World's Refugees: Human Displacement in the New Millennium*. (Oxford: Oxford University Press).

- U.S. Committee for Refugees (1996). *World Refugee Survey*. (Washington, D.C.: Immigration and Refugee Services of America).
- ____ (2001). *Getting Home is Only Half the Challenge: Refugee Reintegration in War Ravaged Eritrea*. (<http://www.unhcr.org/refworld/docid/3bc19092d.html>) [accessed 30 April 2009]
- Willson, Stephen J. (1998). "Long-term Behavior in the Theory of Moves," *Theory and Decision*. 45: 201-240.
- Zetter, Roger (1999). "International Perspectives on Refugee Assistance," in Alastair Ager, ed., *Refugees: Perspectives on the Experience of Forced Migration*. (London: Pinter) 46-82.

Figure 1: Game Tree for Eritrea (with n = 4)

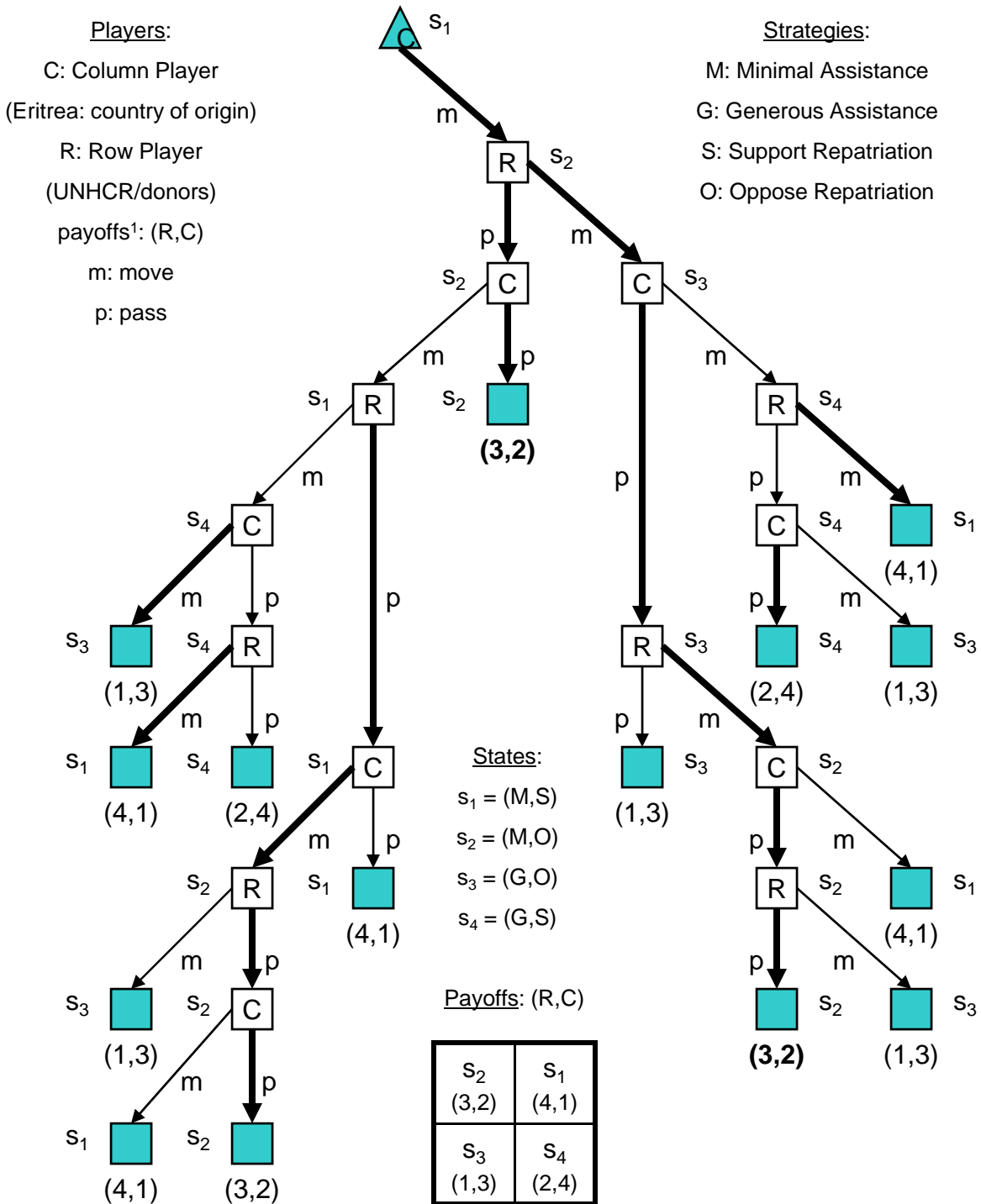

¹Payoffs are ordinal, with higher numbers indicating more desirable outcomes. Choices made using backwards induction are in **bold**. Note that in ToM, two branches from the same node can lead (ultimately) to the same payoffs, so both arrows from a node can be bold.

Figure 2: First Hypothetical Game Tree for Eritrea¹
(3x2 case with n = 4)

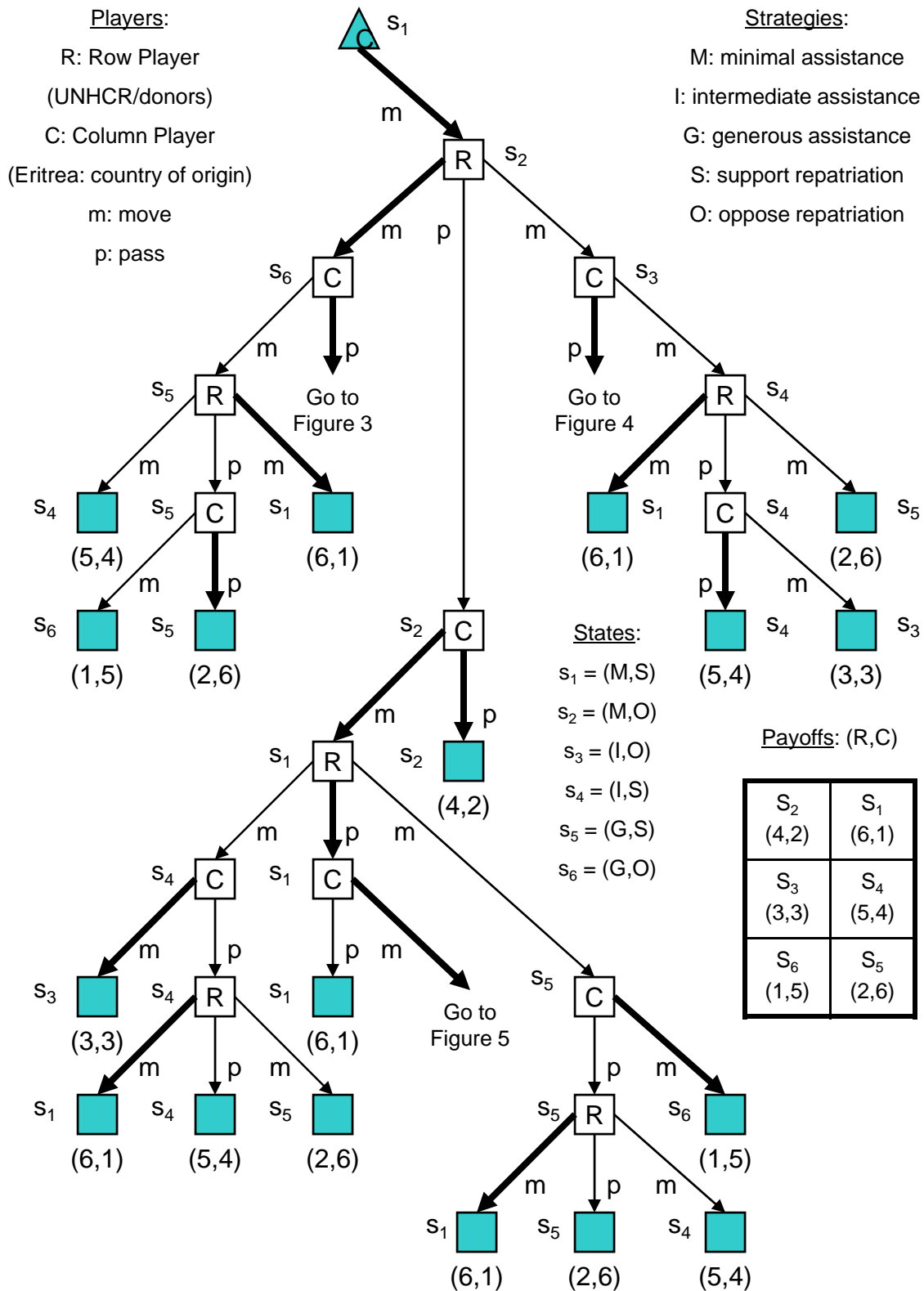

¹The states are numbered from the upper right cell, with C as the first mover and alternating moves by R and C thereafter to the lower left cell. Optimal choices (including ties) are in **bold**.

Figure 3: Module A in First Hypothetical Game Tree

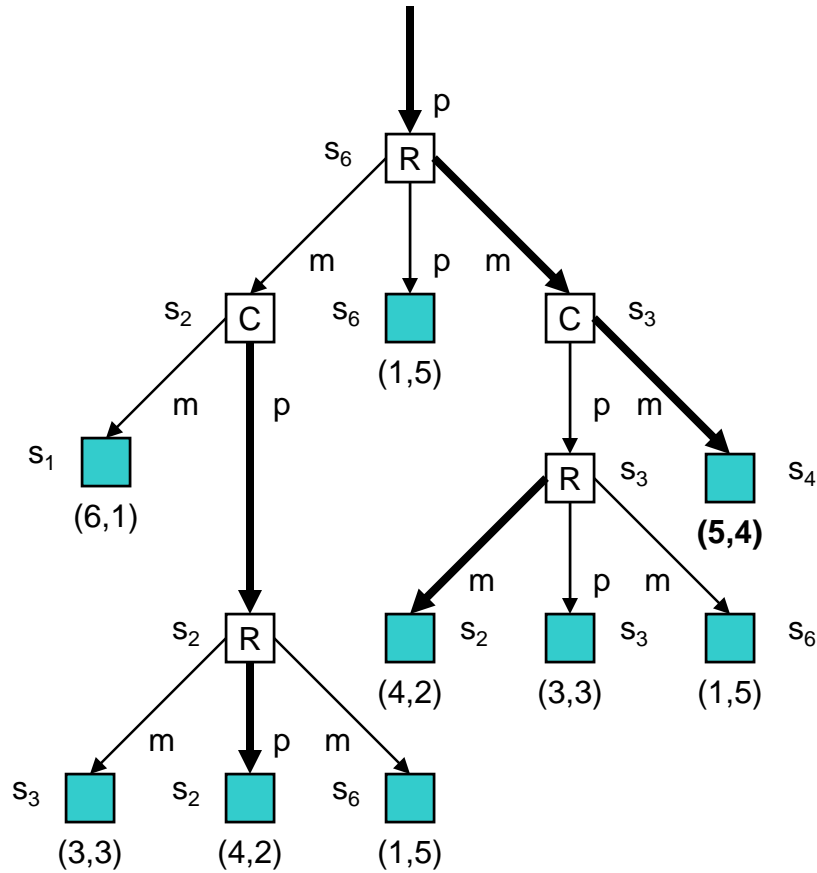

Players:

R: Row Player
 (UNHCR/donors)
 C: Column Player
 (Eritrea: country of origin)
 m: move
 p: pass

States:

s₁ = (M,S)
 s₂ = (M,O)
 s₃ = (I,O)
 s₄ = (I,S)
 s₅ = (G,S)
 s₆ = (G,O)

Strategies:

M: minimal assistance
 I: intermediate assistance
 G: generous assistance
 S: support repatriation
 O: oppose repatriation

Payoffs: (R,C)

s ₂ (4,2)	s ₁ (6,1)
s ₃ (3,3)	s ₄ (5,4)
s ₆ (1,5)	s ₅ (2,6)

Figure 4: Module B in First Hypothetical Game Tree

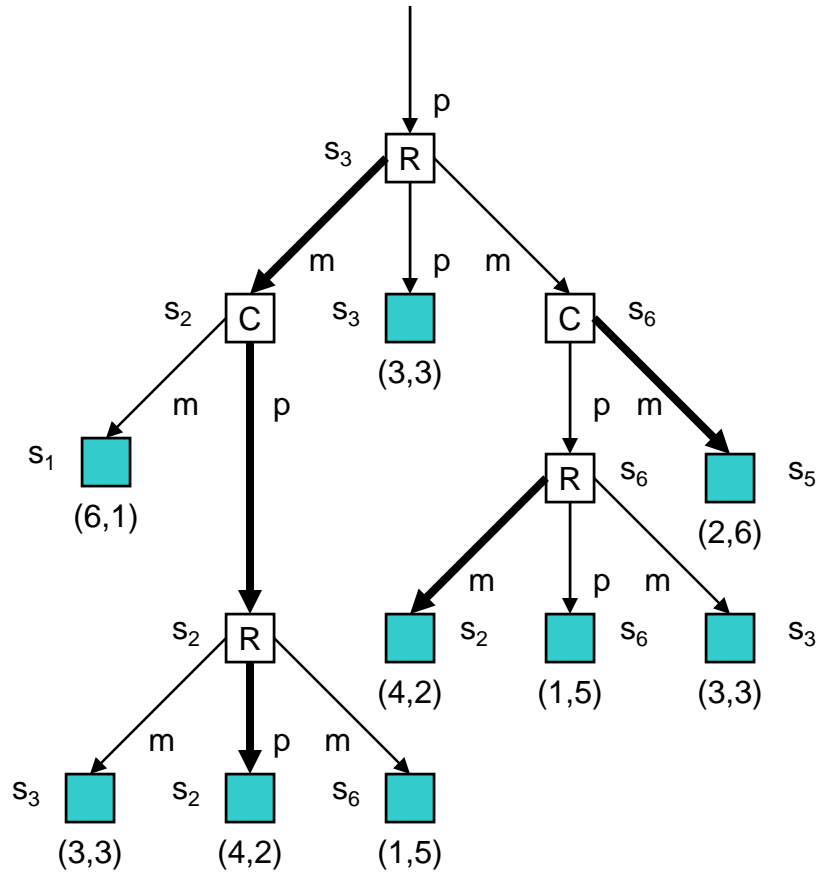

Players:

R: Row Player
 (UNHCR/donors)
 C: Column Player
 (Eritrea: country of origin)
 m: move
 p: pass

States:

s₁ = (M,S)
 s₂ = (M,O)
 s₃ = (I,O)
 s₄ = (I,S)
 s₅ = (G,S)
 s₆ = (G,O)

Strategies:

M: minimal assistance
 I: intermediate assistance
 G: generous assistance
 S: support repatriation
 O: oppose repatriation

Payoffs: (R,C)

S ₂ (4,2)	S ₁ (6,1)
S ₃ (3,3)	S ₄ (5,4)
S ₆ (1,5)	S ₅ (2,6)

Figure 5: Module C in First Hypothetical Game Tree

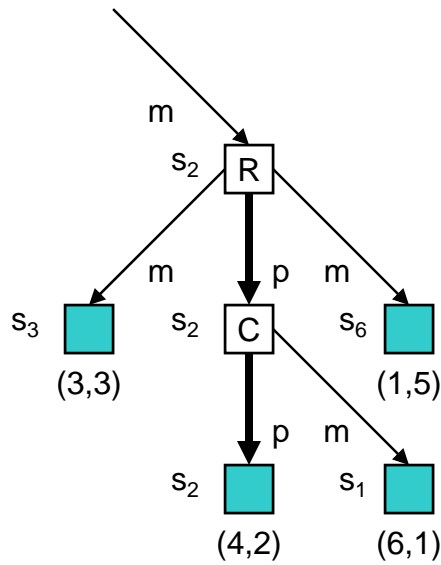

Players:

R: Row Player
 (UNHCR/donors)
 C: Column Player
 (Eritrea: country of origin)
 m: move
 p: pass

States:

s₁ = (M,S)
 s₂ = (M,O)
 s₃ = (I,O)
 s₄ = (I,S)
 s₅ = (G,S)
 s₆ = (G,O)

Payoffs: (R,C)

Strategies:

M: minimal assistance
 I: intermediate assistance
 G: generous assistance
 S: support repatriation
 O: oppose repatriation

S ₂ (4,2)	S ₁ (6,1)
S ₃ (3,3)	S ₄ (5,4)
S ₆ (1,5)	S ₅ (2,6)

Figure 6: Second Hypothetical Game Tree for Eritrea¹
 (3x2 case with n = 4)

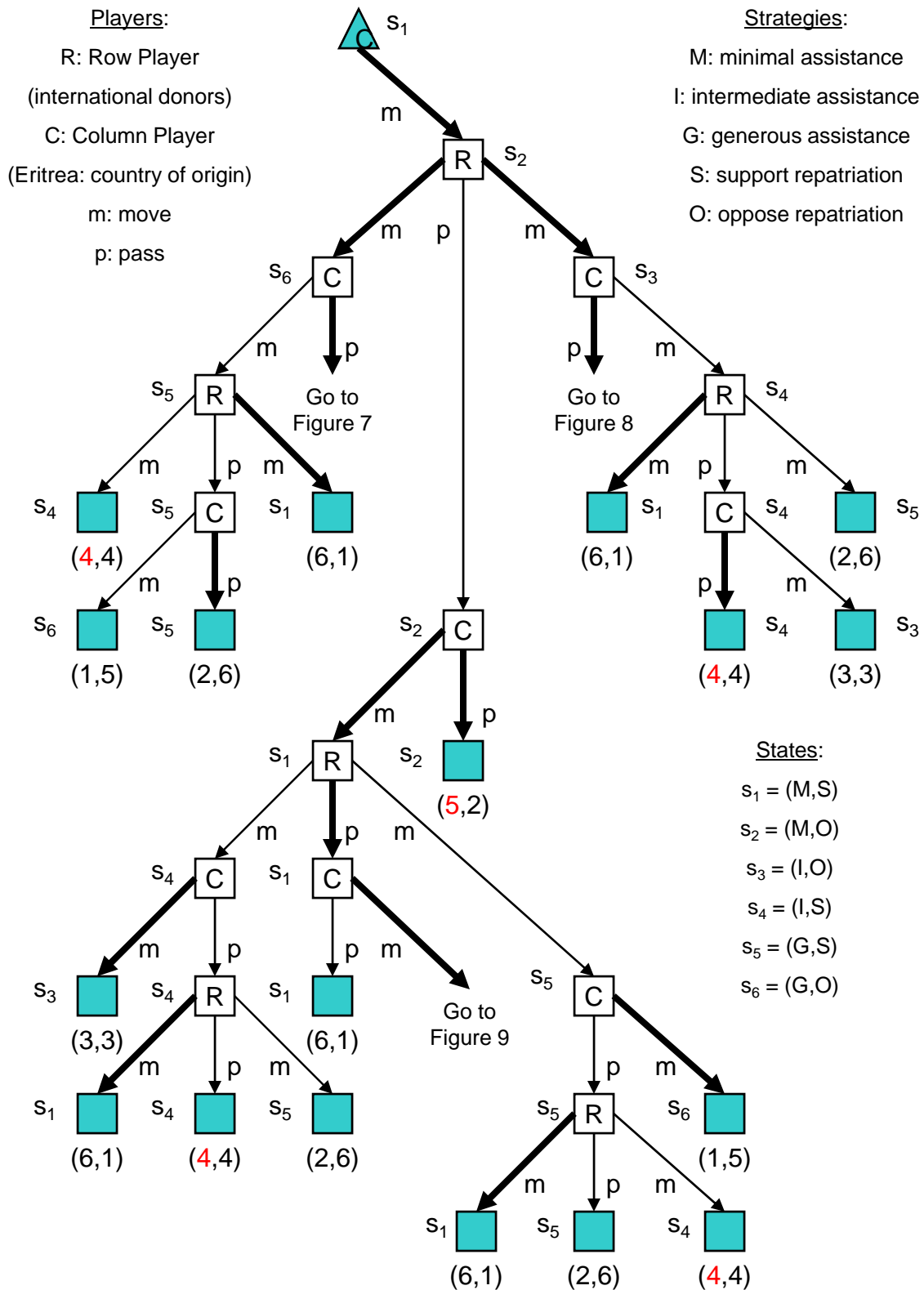

¹The states are numbered from the upper right cell, with C as the first mover and alternating moves by R and C thereafter to the lower left cell. Optimal choices (including ties) are in **bold**.

Figure 7: Module A in Second Hypothetical Game Tree

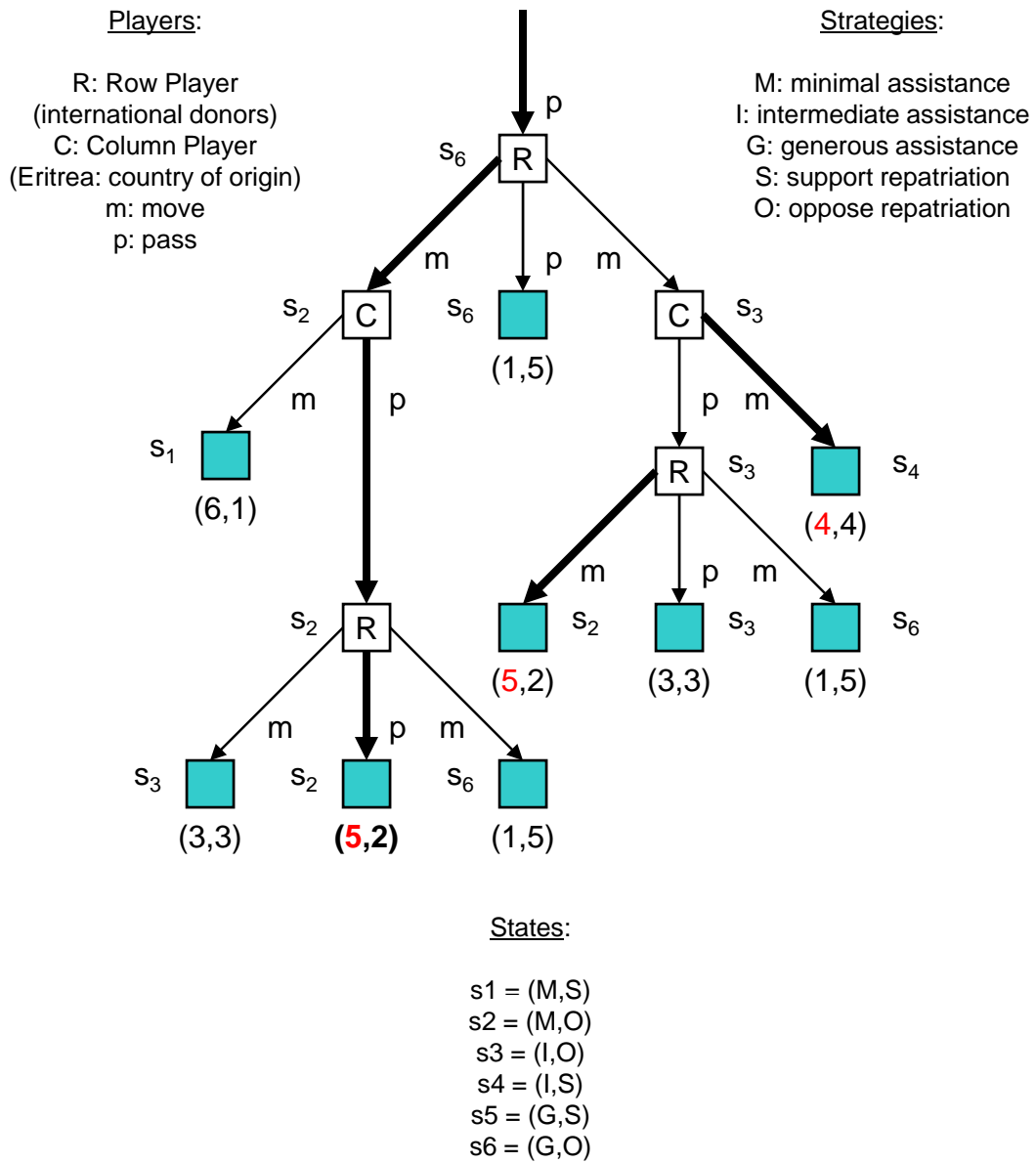

Figure 8: Module B in Second Hypothetical Game Tree

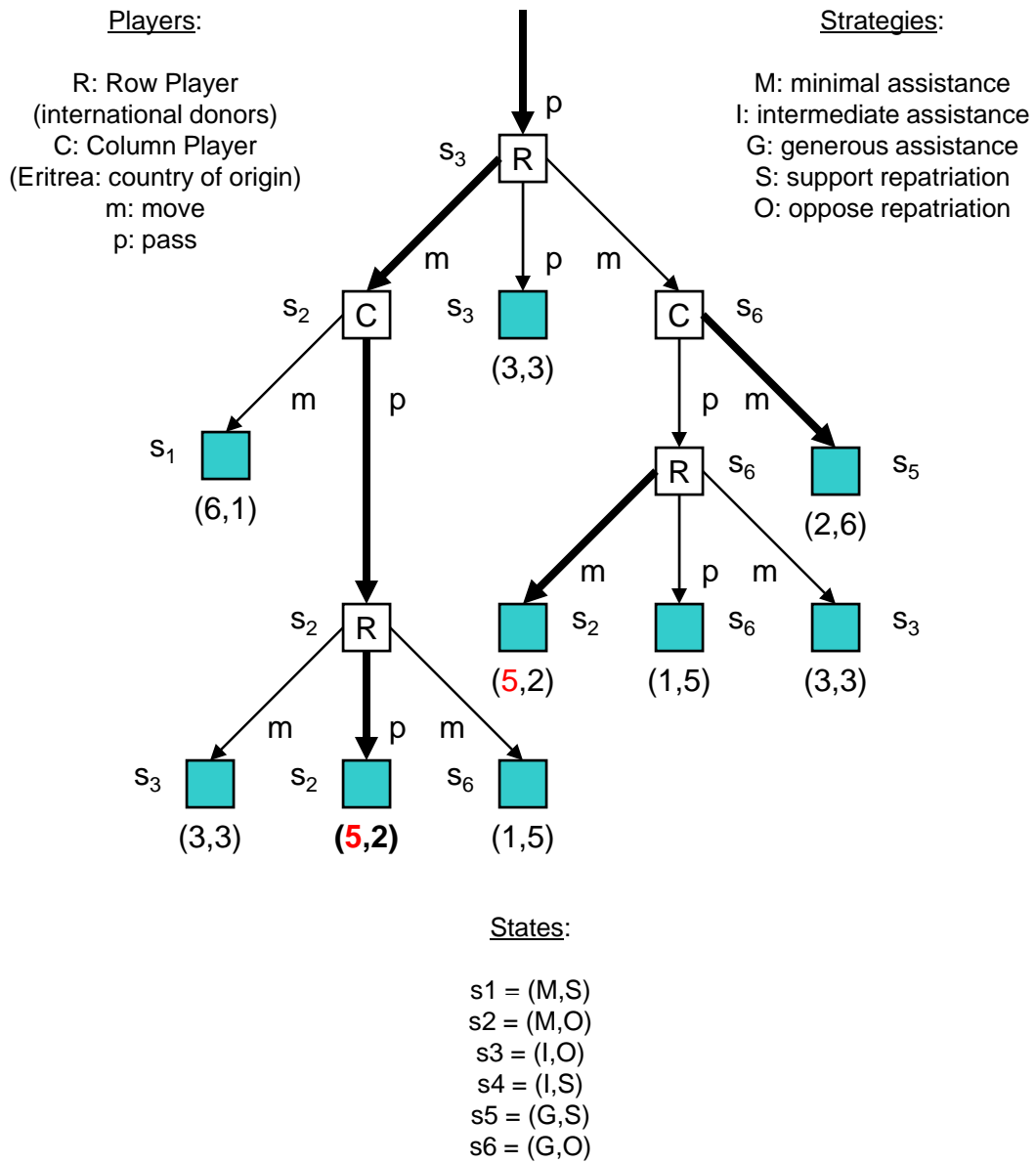

Figure 9: Module C in Second Hypothetical Game Tree

